

**This Page Is Inserted by IFW Operations
and is not a part of the Official Record**

BEST AVAILABLE IMAGES

Defective images within this document are accurate representations of the original documents submitted by the applicant.

Defects in the images may include (but are not limited to):

- **BLACK BORDERS**
- **TEXT CUT OFF AT TOP, BOTTOM OR SIDES**
- **FADED TEXT**
- **ILLEGIBLE TEXT**
- **SKEWED/SLANTED IMAGES**
- **COLORED PHOTOS**
- **BLACK OR VERY BLACK AND WHITE DARK PHOTOS**
- **GRAY SCALE DOCUMENTS**

IMAGES ARE BEST AVAILABLE COPY.

**As rescanning documents *will not* correct images,
please do not report the images to the
Image Problem Mailbox.**



Europäisches Patentamt
European Patent Office
Office européen des brevets

Publication number:

**0 070 811
A1**

EUROPEAN PATENT APPLICATION

Application number: 82830173.9

Int. Cl.³: B 66 F 3/30, F 15 B 15/26

Date of filing: 15.06.82

Priority: 21.07.81 IT 4894381

Applicant: **SELENIA INDUSTRIE ELETTRONICHE ASSOCIATE S.p.A.**, Via Tiburtina, KM 12.400, I-00131 Roma (IT)

Date of publication of application: 26.01.83
Bulletin 83/4

Designated Contracting States: DE FR GB NL SE

Inventor: **Peruzzi, Armando**, Via Pisino, 6, I-00177-Roma (IT)

54 Hydraulic jack with mechanical safety block.

57 To block the piston (4) in any position of its travel, the piston and relative stem (4') has a cavity which extends axially from the surface of the piston head for a length approximately equal to the travel of the piston. Within the said cavity there is a spherical turning screw (6) fixed to the centre of the bottom wall of the said cavity. The said screw is engaged in a reversible manner with its collar (8) which is fixed to the extremity of a hollow shaft (10) which protrudes beyond the cylinder head wall (12) of the jack. To the projecting terminal piece (24) is fixed a free wheel (26) of which one part is keyed into the said terminal piece and the other part is a ring with a toothed profile. A blocking catch with an anti-engagement system may be engaged by hydraulic or manual command in the teeth of the said toothed profile.

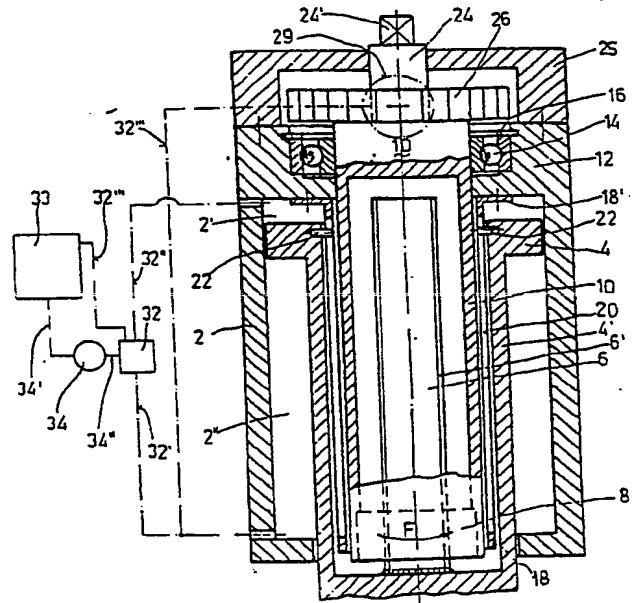

EP 0 070 811 A1

- 1 -

HYDRAULIC JACK WITH MECHANICAL SAFETY BLOCK

DESCRIPTION

This invention relates to a mechanical device applied to a hydraulic jack to obtain a mechanical safety block even in loss of hydraulic power in any position of the travel permitted by the jack.

The application of a mechanical block up-to-date has had the sole and precise
5 function of maintaining jacks used for supporting and raising mechanical structures at the desired positions of travel over a period of time.

That is due to the fact that a jack by its nature cannot maintain its position of travel in time from the moment that the holding of the OR gaskets is not perfect to the point of hermetically sealing the hydraulic chambers from one another and from
10 the outside.

An attempt has been made to resolve this problem by applying large screws (without or within the jack) to be screwed up to the mechanical stop, after having hydraulically positioned the jack itself. But as this operation is manual and not automatic, when it necessary to proceed to the reverse manoeuver it is first
15 necessary to remove the mechanical stop (unscrewing the said screws) and then proceed to the hydraulic action. Clearly for jacks with a long travel, these operations engage the operator for a long time and if the operational sequence is not respected (disengaging of the mechanical block before the hydraulic action)

there is a risk of exciting the mechanical and hydraulic components of the jack in vain.

The first purpose of the present invention is to overcome these risks and dead times (particularly important in a field military system) by rendering this
5 operation automatic and immediate.

The second purpose of this invention is also to resolve the problem of the safety of the manoeuver, which upto now has been resolved with the application of hydraulic valves which block the outflow of oil in the case of a break in the tubes. Infact the application of these valves while being made obligatory by the
10 organisations concerned with the prevention of accidents and safety at work such as ENPI has two disadvantages:

- a) The preparatory operation is often laborious.
- b) These valves do not completely perform their safety role because they do not
15 intervene on the failure of 'OR' gaskets or any component of the cylinder (connectors and rigid tubes) placed before them.

Clearly the use of a mechanical type block as in this invention not involving the use of the said valves avoids any preparatory operation and offers guarantees of safety in the event of any hydraulic failure.

This has been achieved in the invention by the formation within the piston and the
20 relative jack stem of a cylindrical cavity coaxial with them which extends from the surface of the piston head for a length practically equal to the travel of the piston. On the bottom of the said cavity there is fitted a spherical turning screw also placed co-axially and coupled with its fixed collar to the end of a hollow shaft which, starting from the collar, extends to and passes through the jack horizontal
25 cylinder head and projects from it terminating in a gripping attachment capable of causing the shaft to rotate manually when necessary.

As the spherical turning screw and collar form a reversible coupling part of the axial thrust produced by the hydraulic pressure which acts on the jack piston is transformed to a twisting moment. Thus the same hydraulic pressure which acts

on the jack piston when it displaces the piston also causes the said hollow shaft to rotate.

The latter on its appendix inserted between the shaft true and proper and the said gripping attachment carries a blockable free wheel which allows the rotation of
5 the hollow shaft in one direction only.

An anti-rotation slotted tube solid with the jack cylinder and interposed between the said hollow shaft and the wall of the said cavity of the piston prevents the rotation of the piston itself which would occur by reaction in the opposite direction to the rotation of the hollow shaft during the reciprocal screwing
10 between the said spherical turning screw and its collar. Infact two pins solid with the piston are engaged in two longitudinal slots of the said anti-rotation tube. In this way the following advantages are obtained:

- a) in any position whatever of travel a mechanical safety block is ensured from the fact that the free wheel is prevented from rotating in the direction of
15 rotation of screwing up the collar on the thread and therefore the entire re-entry of the jack is prevented mechanically;
- b) it is possible to unwind the jack manually and viceversa, even with the accidental lack of the hydraulics, by rotating the hollow shaft on which the free wheel is mounted by means of a suitable tool, after having unblocked, if
20 necessary, the blockage coupling of the said free wheel;
- c) from a cost point of view the blocking system is certainly competitive with the present systems which are inferior with regard to safety.

In a variation of the invention, in order to use the jack in both directions there is a keying of two free wheels on the hollow shaft, one for each direction of rotation
25 and the same number of blockage couplings. In this way the performance of the jack piston may be gauranteed in every position of travel independently of the forces applied or of a hydraulic failure.

Further advantages and characteristics of the invention will be evident from the following description that refers to the attached figures containing drawings

representing two different but not limitative examples of diverse forms of realization relative to a unidirectional and bidirectional jack respectively.

Referring the figures:

Figure 1 shows a longitudinal section of the unidirectional version of the jack of
5 this invention.

Figure 2 shows the free wheel and relative blocking device for the jack in Fig. 1.

Figure 3 shows a longitudinal section of the bidirectional version of the jack of this invention.

Reference is made to Figures 1 and 2 which represent a first form of realization
10 of the jack of the invention for the application of forces in one direction only and in the particular case of thrust forces. It is formed by a cylindrical body (2) in which is mounted a sliding hollow piston (4) formed by a hollow cylinder with retaining organs not shown. The piston (4) is provided with a large stem (4') in which the cavity of the piston is prolonged for a length approximately equal to the
15 travel of the piston.

The stem (4') passes with a seal through the bottom wall (in the lower part of the figure) of the cylindrical body (2) and terminates in a head, not shown, which can have different forms according to the use of the jack or be interchangeable with heads of another form. At the bottom of the internal cavity of the cylinder (4) and
20 of the stem (4') is fixed a spherical turning screw (6) coaxial with the piston (4) which is coupled with its collar (8), in its turn fixed to the extremity of a hollow shaft (10) which extends to the extremity at the top (at the top of the figure) of the jack passing through a centre hole made in the horizontal wall of the head (12) of the cylinder body. Within the wall (12) is set a system of roller bearings (14) held
25 in position by a spring retaining ring (16).

Between the internal wall of the cylindrical cavity of the piston (4) and the external wall of the hollow shaft (10) is interposed a slotted tube (18) which at one end is provided with a flange (18') fixed solidly to the said head wall (12) of the cylindrical body (2). The slotted tube (18) is provided with two slots (20)
30 diametrically opposite extending for the whole length of the tube and in which two

pins (22) with which the piston is provided are respectively engaged.

The purpose of this coupling is to prevent rotation of the piston (4) with respect to the cylinder (2).

The hollow shaft (10) at the level of the face of the head wall of the cylindrical
5 body (2) is narrowed to form a small shaft (24) on which is mounted a free wheel (26) the external ring (26) of which is free to rotate in one direction only while the internal ring (26'') is solid with the small shaft (24) of the hollow shaft (10). The element (26') has a periphery with a toothed profile and from time to time a pin (28) which may move perpendicularly to the ring (26') by means of a jack (29)
10 may engage in one of the inter-tooth spaces of the said toothed profile.

The said jack (29) is fed from the hydraulic circuit operating the jack when the pin (28) must be removed from the block position while a spring (30) acts in the direction to maintain the pin itself still in the blocked position.

In the realizable form illustrated, to avoid obstacles, the pin (28) is mounted so
15 as to be able to slide with its ends between two inclined slots (27) made from the prongs of a fork (31) placed at the extremity of the rod of the jack (29) and it is maintained in a position of end of course by suitable opposing spring organs not shown in Fig. 2. As will be seen in this figure, where the two positions of block and unblock of the pin (28) are shown, the slots (27) are turned in the same
20 direction of free rotation as the external element (26') and allow the pin itself to move by a sufficient amount to prevent the engaging in every case.

The small shaft (24) is terminated with the square block (24') which may be operated manually with a spanner when it is desired to manipulate the jack by hand.

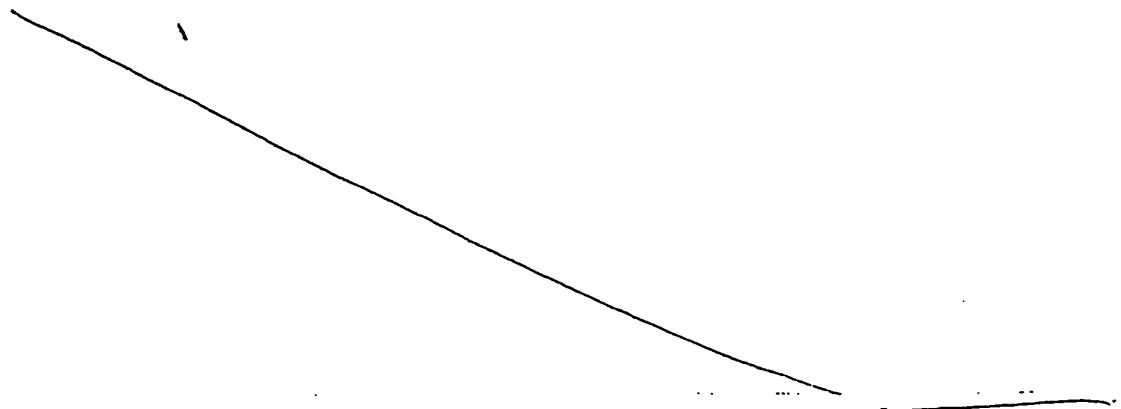

OPERATION

5 During the phase of extension or thrust under load to which all the arrows of Fig. 1 refer the free wheel (26) is maintained in the blocked position by the spring (30). A distributor (32) placed at the output of the jack hydraulic pump (34) sends fluid under pressure to the chamber (2') of cylinder (2) while the oil in the chamber (2'') flows out towards the tank (33) through the line (32') the distributor (32) and

10 the line (32'''). The piston (4) is thrust and is extended taking with it the screw (6) which, being a right hand threaded screw imposes on the collar (8) the rotation indicated by the arrow F (anti-clockwise if seen from the top of the figure). The element (26'') of the free wheel (26) turns also in the anti-clockwise direction. When the desired extension is achieved, the flow of fluid to chamber (2') is

15 interrupted by means of distributor (32). During the re-entry phase, by means of the distributor (32), the line (32'') is connected with the tank (33) by means of line 34' and the line 32' is connected with the pump 34 by means of line 34''. The first effect is that the block of the free wheel (26) is removed, after which the fluid which flows to the chamber (2'') of the cylinder causes the piston (4) to re-enter.

20 In case of loss of hydraulic pressure the block of the free wheel can be removed manually by any means whatever symbolized in Fig. 2 by the handle (40).

What has been said upto now relates to a thrust jack. If it is desired to make the jack function both as thrust and traction jack it is necessary to add another free wheel (46) also fitted to the small shaft (24) and operating in the opposite direction

25 to the free wheel (26). Also the free wheel (46) will be provided with a blocking device analogous to that indicated by 28, 29, 30 and 40 in Fig. 2.

The hydraulic circuit in this case is obviously modified since with the presence of two free wheels one of them must be maintained in the unblocked position when the other is working. For example supposing that the jack must develop a thrust with the

30 extension of the piston as occurs in the case of Figs 1 and 2, the element (26') of the free wheel (26) will be blocked by the spring (30) while the corresponding element of the free wheel (46) will be unblocked by the same fluid under pressure that acts on the head of the piston caused to act in

the jack which commands the blocking wedge of the free wheel (46). In the successive phase of re-entry of the piston the element (26') will be unblocked by the same fluid that acts under the piston while simultaneously the corresponding element of the free wheel (46) will be blocked. If the jack must develop a traction
5 force what has been said regarding the free wheel (26) is applied to the free wheel (46) and viceversa.

All this will be achieved with a suitable control incorporated in the distributor (32).

In Fig. 3 a device is shown to manually control the jack by operating at the side
10 instead if at the head as is the case in Fig. 1.

It consists of a small shaft (48), perpendicular to the axis of the jack, introduced into a cover (50) placed over the head of the jack and fixed to it by a means not shown.

At the end of the small shaft (48) outside the cover (50) there is a square key (48)
15 for applying a handle or similar instrument and at its end inside the cover the small shaft (48) is provided with a conical pinion (52) which meshes with a similar pinion keyed to the head of the small shaft (24). This solution for rotating the hollow shaft manually is indispensable in this case due to the eye fastening (54), similar to the fastening (56) at the other extremity of the jack, with which the jack
20 head is fitted.

Nevertheless a solution of this sort can be useful also in the realized form of the version in Figs 1 and 2.

So two preferred realizable forms of the invention have been described. It will be appreciated how the experts in the field may be able to introduce modifications and
25 variations of various kinds. Nevertheless with the claims that follow it is intended to protect all the modifications and variations that enter with the informative spirit of the invention.

CLAIMS

1. Hydraulic jack comprising a cylinder provided at one end with a horizontal head wall and at the other end with a horizontal bottom wall in which is made an opening through which the stem of a piston passes under seal freely, sealed in the said cylinder on which said piston a fluid under pressure can be
5 made to act, characterized by the fact:
that the said piston and relative stem are hollow and that this cavity extends from the surface of the piston head to a depth substantially equal to the travel of the piston;
that at the centre of the bottom wall of the stem is fixed a spherical turning
10 screw which engages with the relative collar fixed at the end of a hollow shaft which surrounds the said screw, the said shaft passes through a hole in the wall of the cylinder head and is mounted so that it will turn on the said cylinder head wall;
that a cylindrical tube fixed to the said wall extends from it almost down to
15 the centre of the bottom wall of the piston the said tube being provided with two slots diametrically opposite which extend for the whole length of the tube and in which slots are engaged respectively two pins fixed to the inside wall of the piston;
that on the end of the said hollow shaft outside the cylinder head is mounted
20 a free wheel of which one element is solid with the said hollow shaft and the other element is blockable.
2. Jack as in Claim 1 in which the said second element is a ring with a toothed profile and its rotation is blockable by means of a removable pin in the plane
25 in which the element lies perpendicular to the axis of rotation of the element itself so that it is inserted between one tooth and the next.
3. Jack as in Claim 2 in which the said pin is connected to the rod of a hydraulic jack and is provided with a bar on which a spring, placed between the pin and the operating jack of the same, operates.

4. Jack as in Claims 2 and 3 characterized by the fact that the said pin is mounted so as to slide with its two ends within two slots made in the prongs of a fork at the end of the said rod at least one spring element maintaining the said pin in a end-of-run position.
- 5 5. Jack as in Claim 1 characterized by the fact that it is provided with a further free wheel also keyed to the projecting end part of the jack cylinder, the said further free wheel being mounted so as to operate in the opposite way to the said free wheel.

1/2

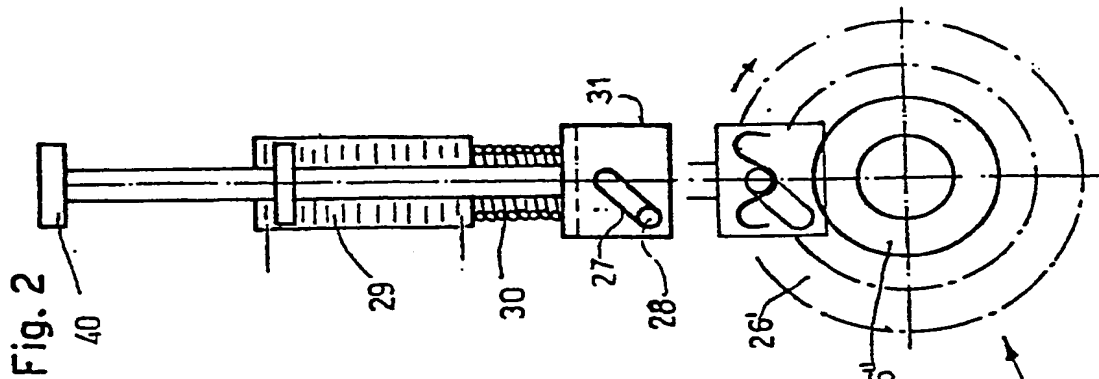

Fig. 2

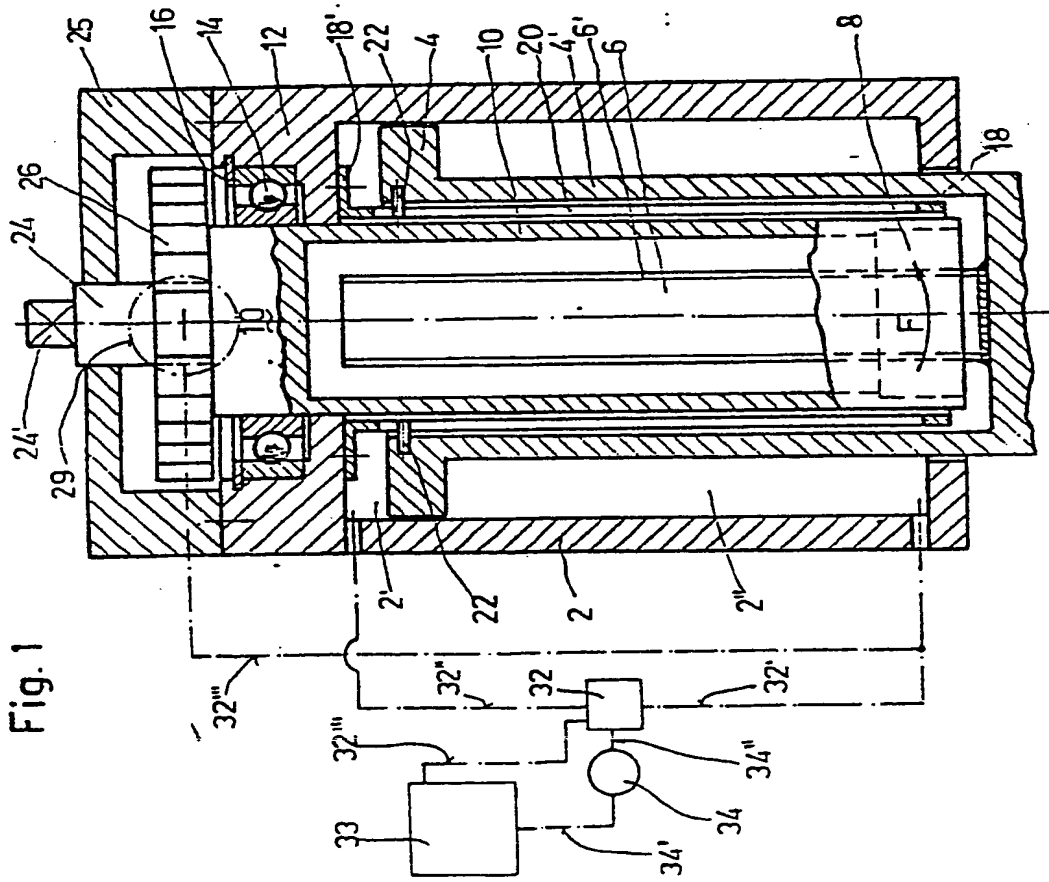
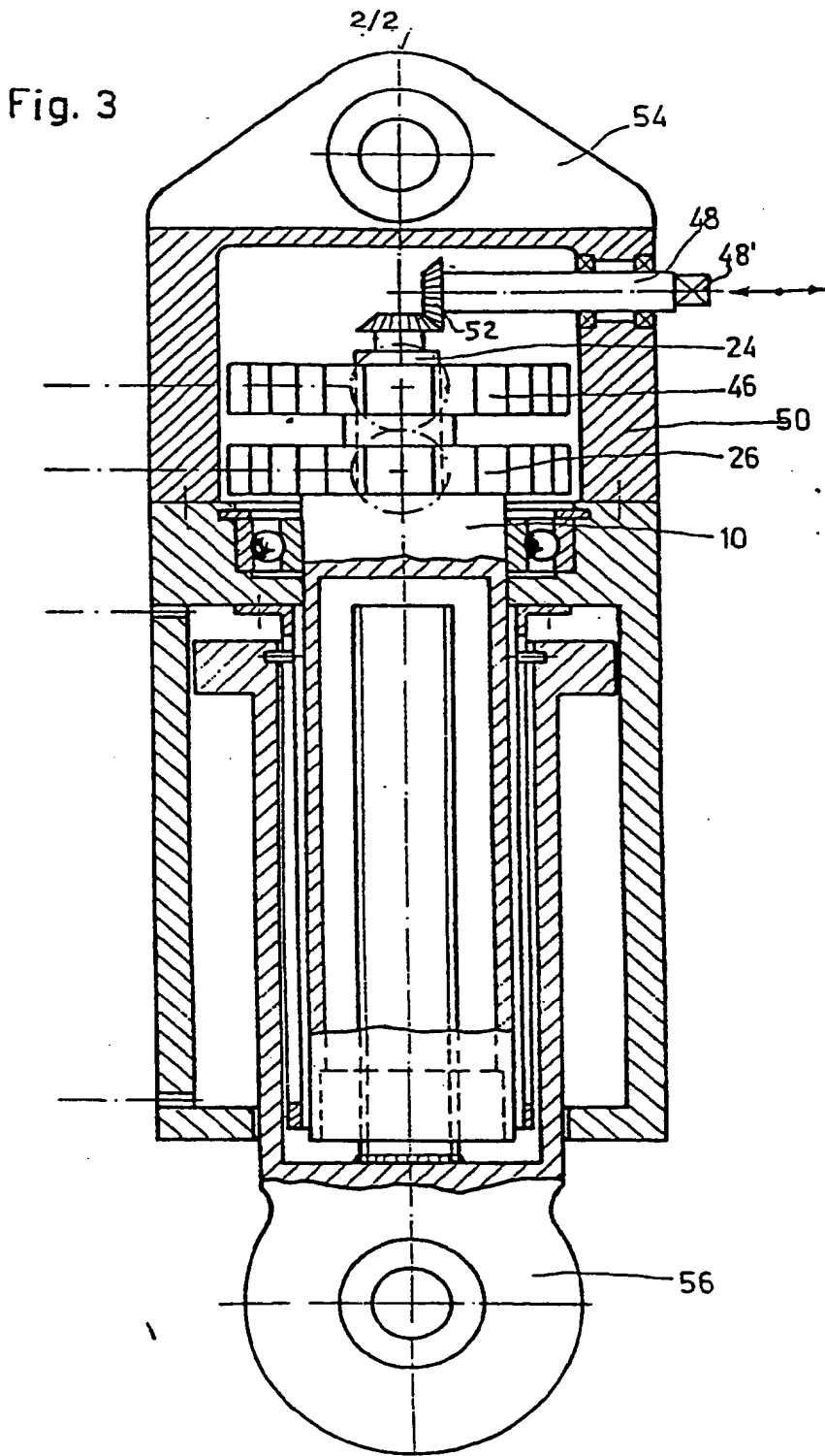

Fig. 1





European Patent
Office

EUROPEAN SEARCH REPORT

0070811

Application number

EP 82 83 0173.9

DOCUMENTS CONSIDERED TO BE RELEVANT			CLASSIFICATION OF THE APPLICATION (Int. Cl. 3)
Category	Citation of document with indication, where appropriate, of relevant passages	Relevant to claim	
Y US - A - 3 603 212 (GEYER)	1	B 66 F 3/30
A	* claim 1; fig. 1 to 5 *	2,5	F 15 B 15/26
Y US - A - 2 979 034 (GEYER)	1	
A	* claim 1 ; fig. 1 *	5	
Y US - A - 4 076 208 (OLSON)	1	
	* claim 1 ; fig. 2, 2A *		
Y US - A - 3 026 850 (CLIFTON et al.)	1	
	* claim 1 ; fig. 1 *		
A US - A - 3 472 124 (ROSELIUS et al.)	1	B 66 F 3/00 F 15 B 15/00
	* fig. 1 *		
A. DE - A - 2 034 826 (PNEUMO DYNAMICS CORP.)	1	
	* claim 5 ; fig. 2, 3 *		
	& US - A - 3 621 763		
A DE - B - 1 071 314 (FISCHER)	1	
	* fig. 1, 2 *		
A DE - B - 1 202 957 (FRIESEKE & HOEPFNER GMBH)		
A DE - B - 1 244 362 (R. COSTAIN LTD.)		
<input checked="" type="checkbox"/> The present search report has been drawn up for all claims			TECHNICAL FIELDS SEARCHED (Int. Cl. 3) CATEGORY OF CITED DOCUMENTS X: particularly relevant if taken alone Y: particularly relevant if combined with another document of the same category A: technological background O: non-written disclosure P: intermediate document T: theory or principle underlying the invention E: earlier patent document, but published on, or after the filing date D: document cited in the application L: document cited for other reasons &: member of the same patent family, corresponding document
Place of search	Date of completion of the search	Examiner	
Berlin	13-10-1982	KANAL	

THIS PAGE BLANK (USPTO)



**RAPPORT DE RECHERCHE
PRÉLIMINAIRE**

établi sur la base des dernières revendications
déposées avant le commencement de la recherche

N° d'enregistrement
national

FA 602753
FR 0102588

DOCUMENTS CONSIDÉRÉS COMME PERTINENTS		Revendication(s) concernée(s)	Classement attribué à l'invention par l'INPI
Catégorie	Citation du document avec indication, en cas de besoin, des parties pertinentes		
X	US 3 823 758 A (HEESE W) 16 juillet 1974 (1974-07-16) * colonne 5, ligne 30 - colonne 8, ligne 44; figures 3,5 *	1-8	F15B15/08 B66F3/30 F15B21/08
X	US 3 026 850 A (CLIFTON JOHN R ET AL) 27 mars 1962 (1962-03-27) * colonne 2, ligne 42 - colonne 3, ligne 7 * * colonne 4, ligne 3-64; figures 1,5 *	1-3,6,7	
X	DE 12 02 957 B (FRIESEKE &HOEPFNER G.M.B.H.) 14 octobre 1965 (1965-10-14) * colonne 3, ligne 23-38; figures 1,2 *	1,2,6,7	
A,D	EP 0 070 811 A (SELENIA IND ELETTRONICHE) 26 janvier 1983 (1983-01-26) * abrégé; figure 1 *	1	
			DOMAINES TECHNIQUES RECHERCHÉS (Int.CL.7)
			F15B
Date d'achèvement de la recherche		Examineur	
8 janvier 2002		Busto, M	
CATÉGORIE DES DOCUMENTS CITÉS			
X : particulièrement pertinent à lui seul Y : particulièrement pertinent en combinaison avec un autre document de la même catégorie A : arrière-plan technologique O : divulgation non-écrite P : document intercalaire		T : théorie ou principe à la base de l'invention E : document de brevet bénéficiant d'une date antérieure à la date de dépôt et qui n'a été publié qu'à cette date de dépôt ou qu'à une date postérieure. D : cité dans la demande L : cité pour d'autres raisons & : membre de la même famille, document correspondant	

THIS PAGE BLANK (USPTO)

**ANNEXE AU RAPPORT DE RECHERCHE PRÉLIMINAIRE
RELATIF A LA DEMANDE DE BREVET FRANÇAIS NO. FR 0102588 FA 602753**

La présente annexe indique les membres de la famille de brevets relatifs aux documents brevets cités dans le rapport de recherche préliminaire visé ci-dessus.
Les dits membres sont contenus au fichier informatique de l'Office européen des brevets à la date du 08-01-2002
Les renseignements fournis sont donnés à titre indicatif et n'engagent pas la responsabilité de l'Office européen des brevets, ni de l'Administration française

Document brevet cité au rapport de recherche		Date de publication	Membre(s) de la famille de brevet(s)		Date de publication
US 3823758	A	16-07-1974	AUCUN		
US 3026850	A	27-03-1962	AUCUN		
DE 1202957	B		AUCUN		
EP 0070811	A	26-01-1983	IT	1142782 B	15-10-1986
			DE	3277581 D1	10-12-1987
			EP	0070811 A1	26-01-1983
			US	4481864 A	13-11-1984

EPO FORM P0485

THIS PAGE BLANK (USPTO)